

WE ARE GLASS PEOPLE

HEYE

2-AXIS SERVO PUSHER

Type 2157



2-AXIS SERVO PUSHER

The 2-axis Servo Pusher Type 2157 is part of the Heye Modular Servo Technology (HMST). It is used at IS-Machines with up to 24 sections – preferably in double gob operation.

Description and function

The advantage compared with pneumatically driven pushers is that the push-out and retract movement of the pusher fingers is carried out controlled and reproducibly.

The Pusher has two independently operating servo axes that act as direct drive. Thus, the axes only need few drive elements.

The modular design renders a simple conversion from right-hand to left-hand operation possible. Hence, the effort for maintenance and repair is considerably reduced.

As the Pusher only consists of a few components the weight is very low. Mounting and demounting are safe and easy to handle.

Depending on the weight of the glass containers and on the production speed the Pusher can be operated without pneumatical means. Thus, there is no risk of bottle deformation by compressed air or vacuum.

By the asymmetric design of the dead plate and by using a 150 mm wide toothed chain the push-out way on the dead plate cross to the machine conveyor is increased so that the glass containers can be directed optimally in transport direction of the machine conveyor and can be accelerated. By it, the centrifugal force of the push-out movement is reduced.

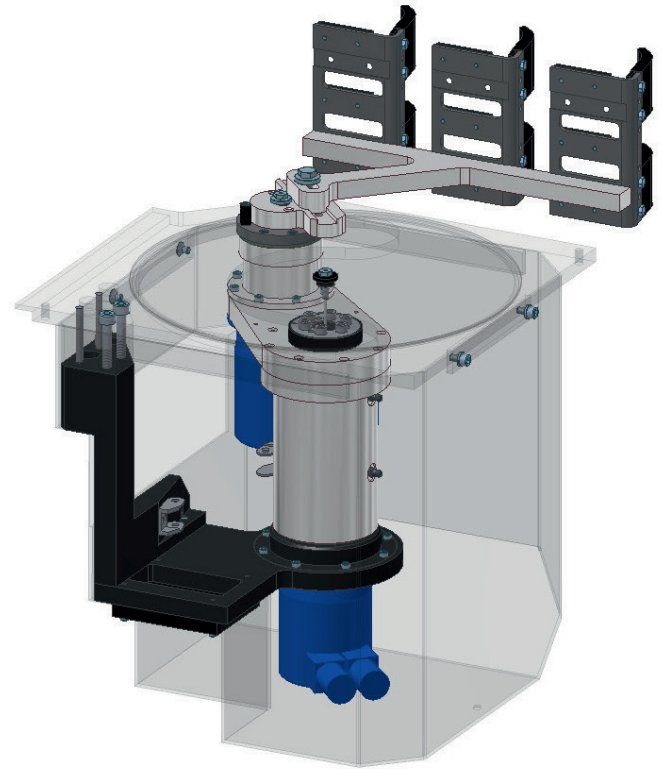

Motion profile of the Pusher and main installation dimensions

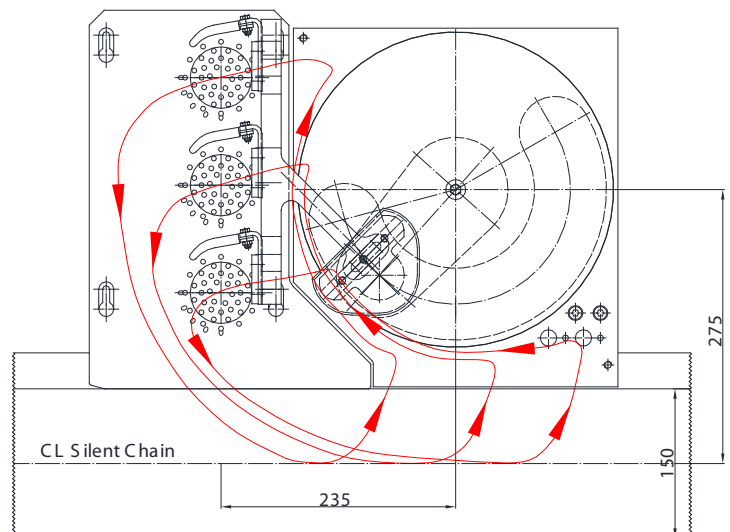

HEYE MODULAR SERVO TECHNOLOGY (HMST)

The HMST is a trend setting drive concept to control servo drives in the IS-Machine and their periphery.

HMST

The modular system design allows a system-specific solution including the option to be upgraded.

The standard system consists of:

- An infeed cabinet and a module cabinet
- A PC with process visualisation and the option to link several Heye Hot End Drives

HMST main menu

You can reach the menu level of a section or of a peripheral device by clicking on the relevant display in the main menu.

Menu of a machine section

The menus of the individual servo mechanisms can be opened by clicking on the corresponding display.

Advantages of the process visualisation

- High availability by an independently operating visualisation and real time control
- Easy access on all parameters
- Article administration for all process parameters allows short job change times
- Error report for all systems connected
- Option to link several Heye Hot End Equipment via CAN-Bus / Ethernet makes the entire system easy-to-follow
- Use of Windows® as operating system on a standard PC

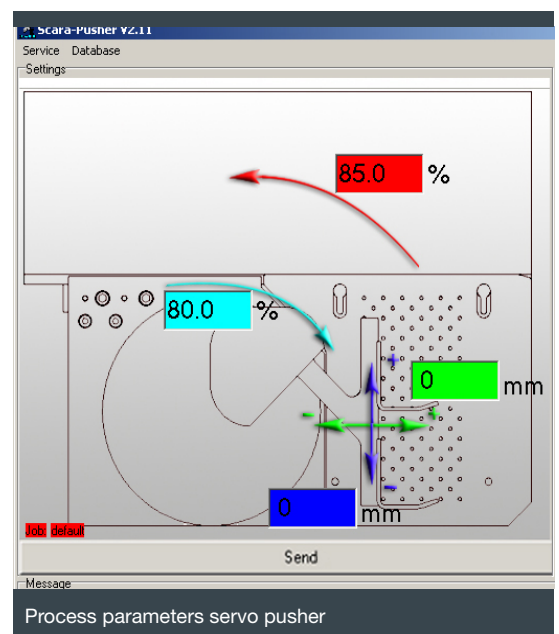
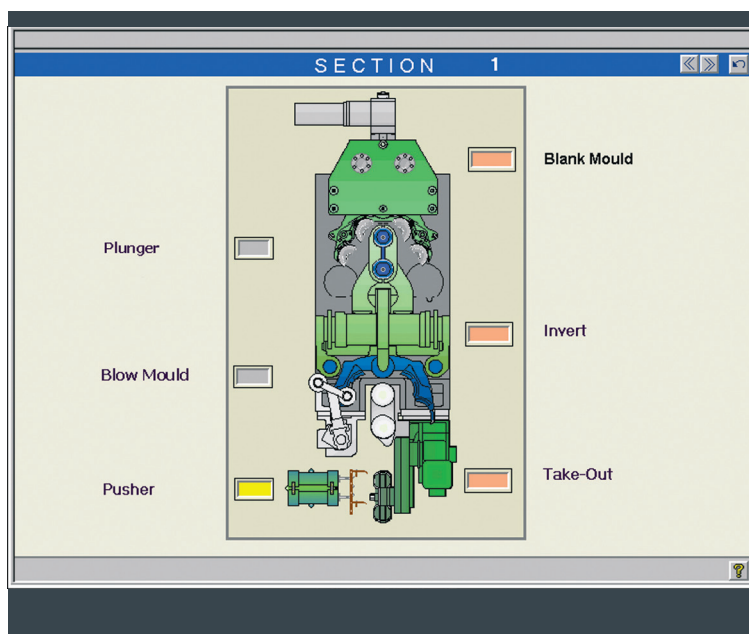

OVERVIEW

Advantages

- Service reduced operation, minimum wear, long lifetime
- Simple operation of the Pusher by setting the parameters via dialogue:
Motion and speed profiles can be adapted to the article geometry and transport speed even during run
- Compressed air to influence the article transport is not obligatory. If, nevertheless, compressed air should be needed due to production speed and weight of the article, "Integrated Pocket Air" is used. For it, the dead plate is equipped with an air distributor.
- Most of the movable parts are located below the machine conveyor level inside the pusher housing and are thus protected against environmental influences such as heat or dirt
- Quick and simple exchange of the entire finger support including fingers
- Robust pusher fingers made of stainless steel ("soft touch" plating on request)
- In case of a collision and thereby resulting position loss the Pusher returns to its home position so that it can be avoided that the bottle transport of the neighbouring sections will be affected. After a blocking the Pusher restarts automatically
- Switching output available to switch the gob off or to stop the section if the Pusher completely fails
- Coupling with any IS E-Timing possible
- Also available for TG applications

Technical Data

- | | |
|--|--|
| ■ Machine conveyor speed | up to 70 m/min |
| ■ Weight of the unit | approx. 30 kg |
| ■ Dimensions of the unit
width / height / depth | 325 / 400 / 326 mm |
| ■ Ambient temperature
for the control cabinet | max. 35°C |
| ■ Dimensions of the control
cabinet
width / height / depth | 800 / 2100 / 600 mm |
| ■ Mains connection | three-phase, 50 Hz with
neutral conductor |
| ■ Voltage | 400 Volt |
| ■ Current consumption | approx. 250 VA per sec. |

Emissions

- The A-weighted permanent sound pressure level of this system is below 70 dB(A)