

WE ARE GLASS PEOPLE

BLOW MOULD AXIAL COOLING 360°

Type 2241

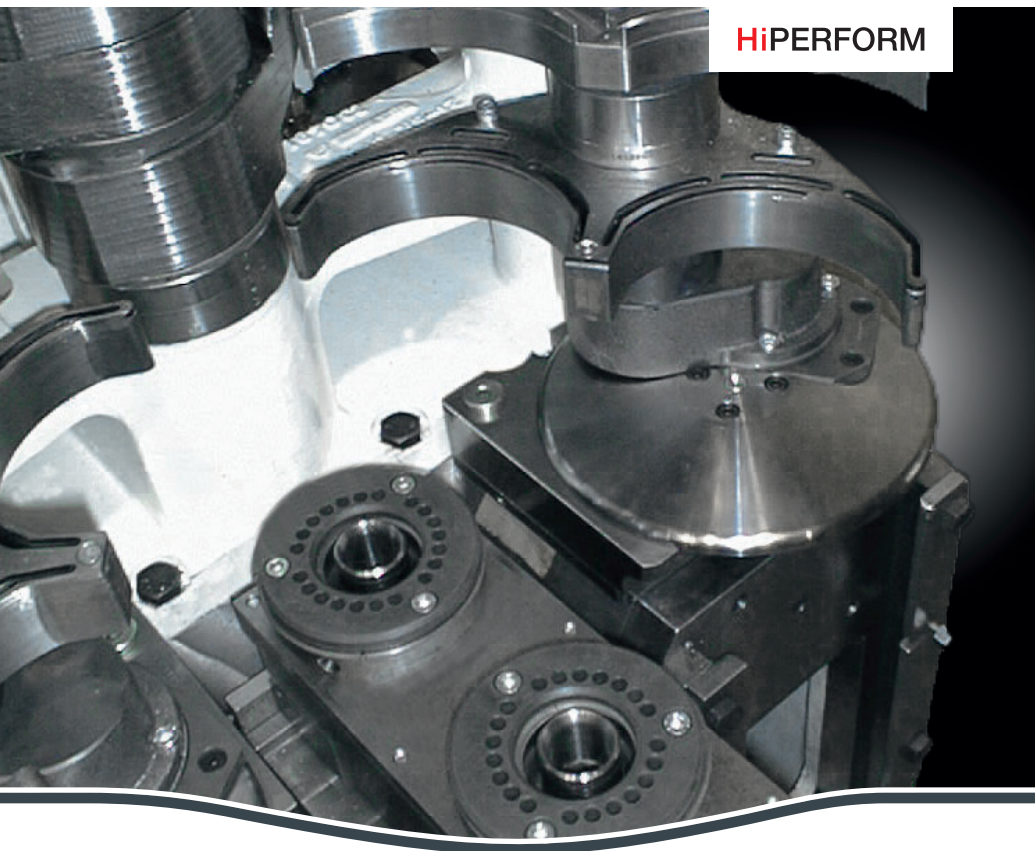

h heye
international

BLOW MOULD AXIAL COOLING (360° COOLING)

The Blow Mould Axial Cooling cools the moulds continuously over the entire process cycle. Thus, compared to other cooling systems a much better cooling performance can be achieved. The cooling is carried out more uniform whereby the stability and quality of the glass containers being produced is influenced positively. Also the production speed can be increased. The Blow Mould Axial Cooling is applicable for 5" DG, 5 ½" DG and 6 ¼" DG IS-Machines.

The axial temperature distribution is determined by the mould design.

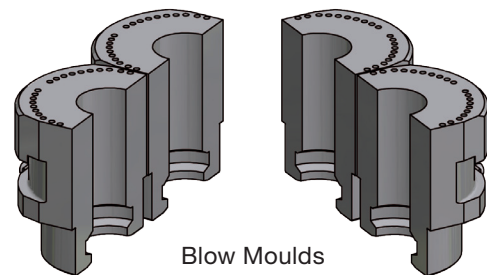

Blow Moulds

The cooling piece design allows a uniform distribution of the cooling air on all axial cooling drillings of the blow mould.

- 1** Mould half
- 2** Mould cooling piece

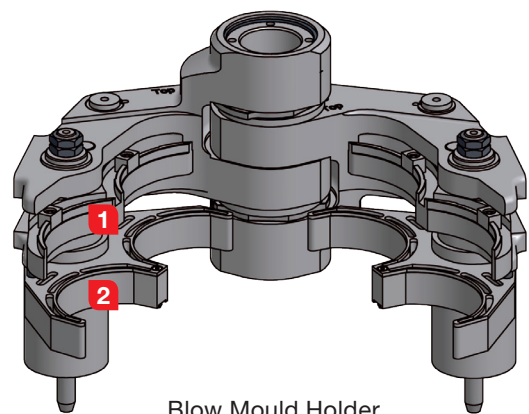

Blow Mould Holder

The supply of cooling air via intermittent valves and turntables allows to adjust the cooling duration from 0° to 360°.

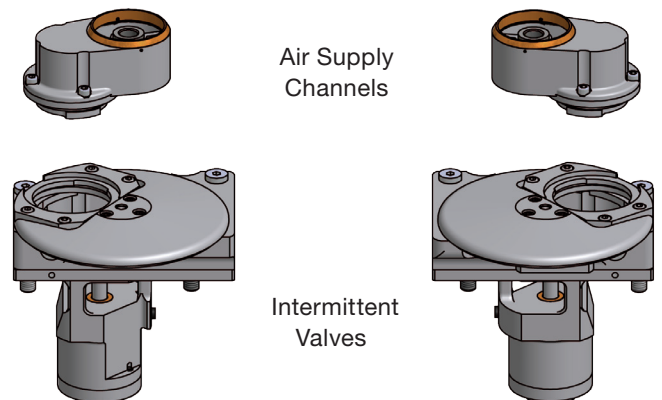

Air Supply Channels

Intermittent Valves

FLEXIBLE BLOW MOULD HOLDER

One blow mould holder for all applications. The blow mould holder can be adapted to different mould sizes.

Depending on the mould size it can either be mounted with one or two mould half pairs.

Blow mould holder with one mould half pair for short moulds

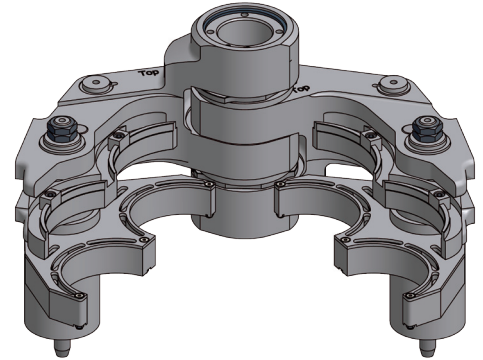

Blow mould holder with two mould half pairs for long moulds

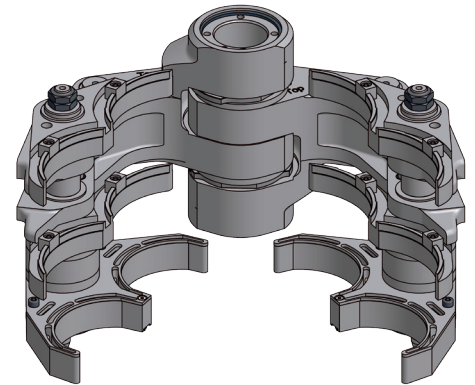

By attaching a spacer and by changing the position of the adapter the blow mould holder can be adjusted in height for long-stroke machines. In this way the height of the pressure points in the mould halves can be adapted.

3 Spacer

4 Adapter

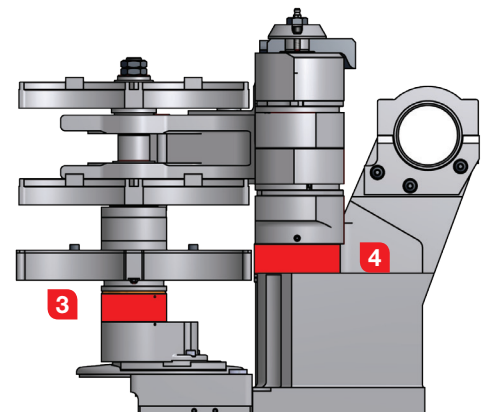
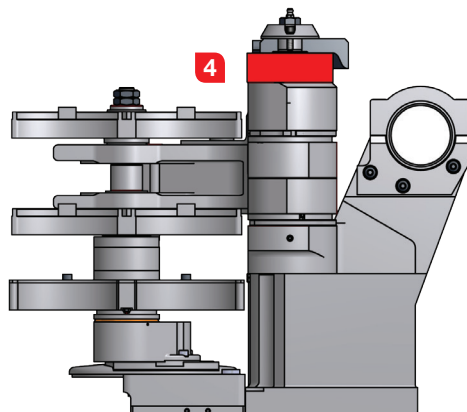

OVERVIEW

Advantages

- Individual cooling air adjustment up to permanent cooling

Scope of Delivery

- Right blow mould air supply
- Left blow mould air supply
- Blow mould air supply channel
- Blow mould holder axial cooling

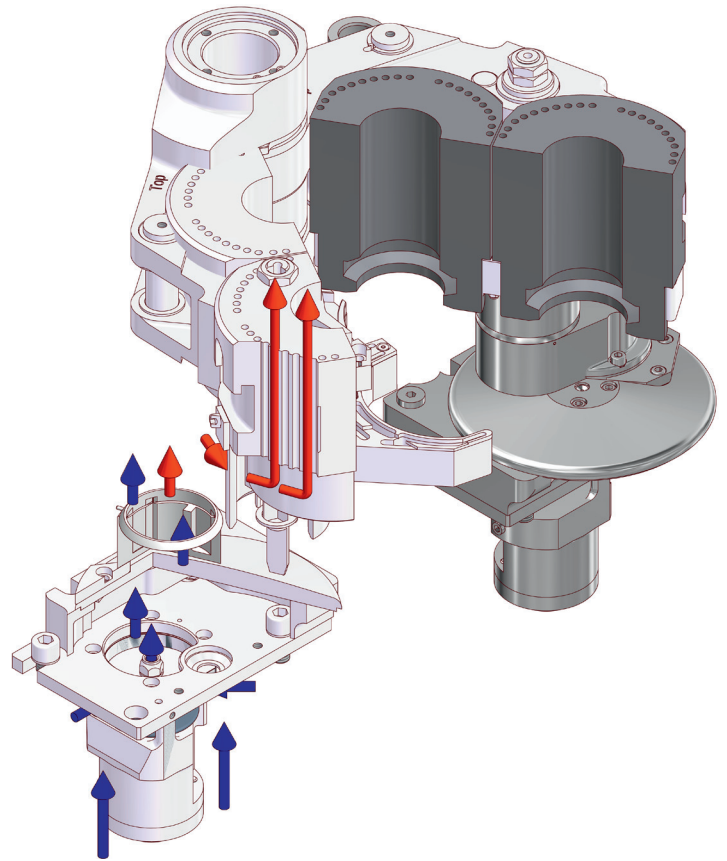

1012/300

Heye International GmbH
Lohplatz 1, 31683 Obernkirchen
Germany

T +49 5724 26 452

F +49 5724 26 229

www.hey-international.com

 **hey**eye
international